

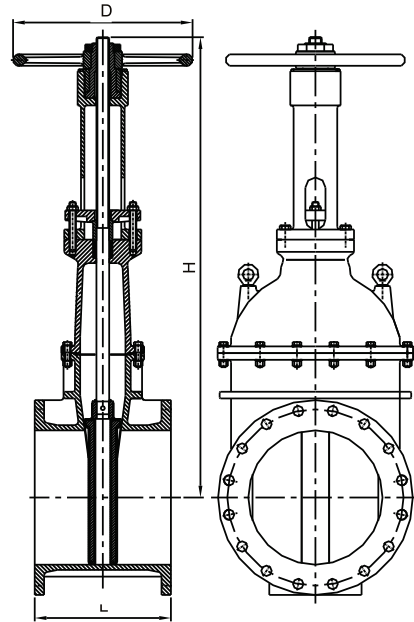

## Schematic Drawing



## Features

- Complies with AWWA C515 Standard
- Heavy duty handwheel and attachment nut
- High quality graphite stem seal
- NPT plug on body
- Flanged to ANSI B16. 1 Class125 (Other flange types available upon request)
- 200PSI Working pressure
- -10°C to 82°C Working temperature
- Corrosion protection - Fusion bonded epoxy coated interior and exterior to AWWA C550 standard

## Notes:

-Design and material are subject to change without notice.

## Dimensions (mm/inch)

Size	500/20"		600/24"	
	mm	inch	mm	inch
L	457	18	508	20
H (Open)	2276	89.51	2600	102.36
H (Close)	1776	69.92	2000	78.74
D	610	24	762	30

## Material Specification

Part Name	Material	ASTM Spec.
Body	Ductile iron	A536 65-45-12
Wedge	Ductile iron	EPDM Encapsulated
Wedge nut	Bronze	B62 C83600
Stem	Stainless steel	AISI 420
Bonnet	Ductile iron	A536 65-45-12
Gasket	Rubber	EPDM
Packing	Graphite	Commercial
Gland	Ductile iron	A536 65-45-12
Yoke Nut	Bronze	B62 C83600
Hand wheel	Ductile iron	A536 65-45-12
Hand wheel Nut	Ductile iron	A536 65-45-12
NPT Plug	Malleable iron	Commercial
Gland Bolt	Stainless steel	AISI 316
Gland Bolt	Carbon steel	A307 B