

## Schematic Drawing

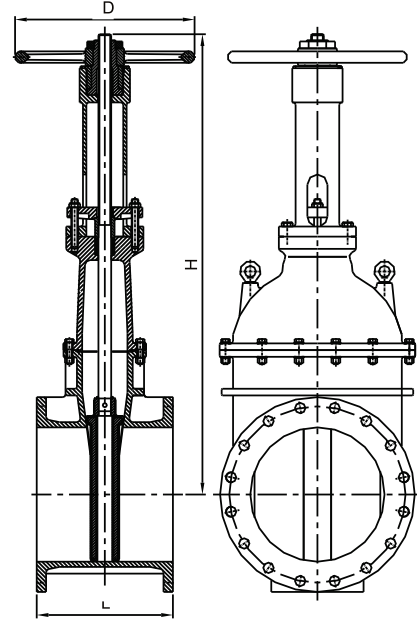

## Features

- Complies with AWWA C515 Standard
- Heavy duty handwheel and attachment nut
- High quality graphite stem seal
- NPT plug on body
- Flanged to ANSI B16. 1 Class125 (Other flange types available upon request)
- 250PSI Working pressure
- -10°C to 82°C Working temperature
- Corrosion protection - Fusion bonded epoxy coated interior and exterior to AWWA C550 standard

## Material Specification

| Part Name      | Material        | ASTM Spec.        |
|----------------|-----------------|-------------------|
| Body           | Ductile iron    | A536 65-45-12     |
| Wedge          | Ductile iron    | EPDM Encapsulated |
| Wedge nut      | Bronze          | B62 C83600        |
| Stem           | Stainless steel | AISI 420          |
| Bonnet         | Ductile iron    | A536 65-45-12     |
| Gasket         | Rubber          | EPDM              |
| Packing        | Graphite        | Commercial        |
| Gland          | Ductile iron    | A536 65-45-12     |
| Yoke Nut       | Bronze          | B62 C83600        |
| Hand wheel     | Ductile iron    | A536 65-45-12     |
| Hand wheel Nut | Ductile iron    | A536 65-45-12     |
| NPT Plug       | Malleable iron  | Commercial        |
| Gland Bolt     | Stainless steel | AISI 316          |
| Gland Bolt     | Carbon steel    | A307 B            |

## Notes:

-Design and material are subject to change without notice.

## Dimensions (mm/inch)

| Size      | 350/14" |       | 400/16" |       | 450/18" |       |
|-----------|---------|-------|---------|-------|---------|-------|
|           | mm      | inch  | mm      | inch  | mm      | inch  |
| L         | 381     | 15    | 406     | 16    | 432     | 17    |
| H (Open)  | 1574    | 61.97 | 1786    | 70.31 | 2020    | 79.53 |
| H (Close) | 1224    | 48.19 | 1386    | 54.57 | 1570    | 61.81 |
| D         | 445     | 17.5  | 535     | 21    | 610     | 24    |