

Schematic Drawing

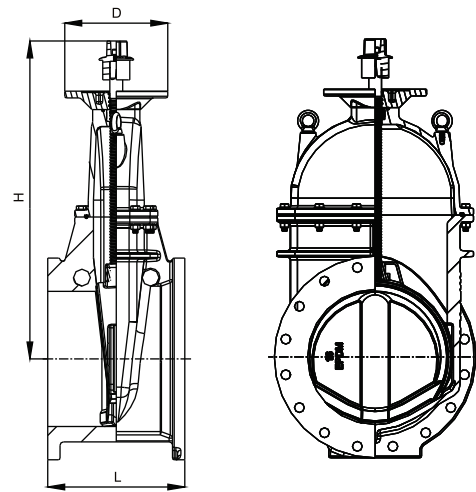

Features

- Complies with AWWA C515 Standard
- NPT plug on body
- 200 PSI Working pressure
- -10°C to 82°C Working temperature
- Ductile Iron Body
- Sizes: 20" & 24"

Notes:

-Design and material are subject to change without notice.

Dimensions (mm/inch)

Size	600/20"		600/24"	
	mm	inch	mm	inch
L	457	18	508	8
H	1120	44.09	1290	50.79
D	305	12	305	12

Material Specification

Part Name	Material	ASTM Spec.
Body	Ductile iron	A536 65-45-12
Wedge	Ductile iron	EPDM Encapsulated
Wedge nut	Bronze	B62 C83600
Stem	Stainless steel	AISI 420
Bonnet	Ductile iron	A536 65-45-12
Gasket	Rubber	EPDM
Packing	Graphite	Commercial
Post Flange	Ductile iron	A536 65-45-12
Thrust Collar	Brass	C67400
O-ring	Rubber	EPDM
Operating nut	Ductile iron	A536 65-45-12
NPT Plug	Malleable iron	Commercial
Post flange bolt	Carbon steel	A307 B
Bonnet bolt	Carbon steel	A307 B